

NATEF

TASK SHEET --- SECTION A5 B4B P-1

A5B4B: Disassemble-reassemble Brake Master Cylinder

Student: _____ Date: _____ Period: _____

VIN: _____ Year: _____ Make: _____ Model: _____

Engine: _____ Transmission: _____ Production Date: _____

OBJECTIVE: Student will disassemble and reassemble the master cylinder from a vehicle, identify all parts, and determine what is necessary to bring it up to manufacturer's specifications.

- MATERIALS:**
1. **EYE PROTECTION**
 2. Hand tools
 3. Specification book or All-Data on-line
 4. Master Cylinder (see instructor)

PROCEDURE: **WEAR EYE PROTECTION!** Student will look up procedure to disassemble and reassemble the master cylinder from a vehicle and print it out and attach it to the back of this task sheet. Student will identify all parts below.

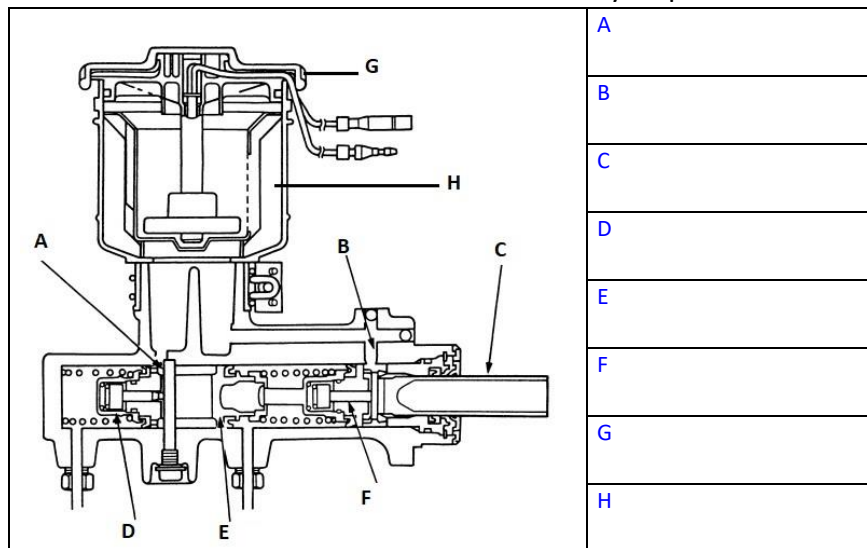

INSTRUCTORS EVALUATION

LEVEL OF SKILL ATTAINED	WORK PROFESSIONALISM	Points
Student can evaluate results and determine necessary action (5)	Documentation Completeness (1)	
Student can interpret outcomes (4)	Safety Compliance (1)	
Student can recall/recite procedure (2)	Floor mats, seat covers, and fender cover (3)	
Student has observed procedure (1)	LEVEL OF SKILL ATTAINED (1-5)	
	TOTAL SCORE	

INSTRUCTOR'S SIGNATURE: