

A6/U10/L1 MISCELLANEOUS SYSTEMS DIAGNOSIS AND REPAIR

JOB SHEET A6H8 R&R DOOR/DASH PANEL

Name: _____ Start Date: _____
Make: _____ Model: _____ End Date: _____
VIN: _____ Year: _____
Mileage: _____

LEARNING OBJECTIVES/NATEF TASK



- Remove and reinstall door panel and instrument panel (dash) panel. **NATEF TASK A6/H8, P1. ICS167**

MATERIALS

Classroom Vehicle (s) OEM service manual, Hand Tools

PROCEDURE

- Wear Safety Glasses for this entire procedure. Locate the procedure for door panel removal for the vehicle you are using and submit this procedure and repair plan to your instructor or mentor for approval.

Your Instructor **MUST** stamp or initial the box to the right before you can proceed with this job sheet.



1. On what page and in what section of the OEM service information did you find the door panel removal procedure? _____
2. Was the OEM service information Internet or Electronic based? _____

A6/U10/L1 MISCELLANEOUS SYSTEMS DIAGNOSIS AND REPAIR

3. Remove the door panel as follows: In the Figure 1 below, Remove the inside handle bezel (2).

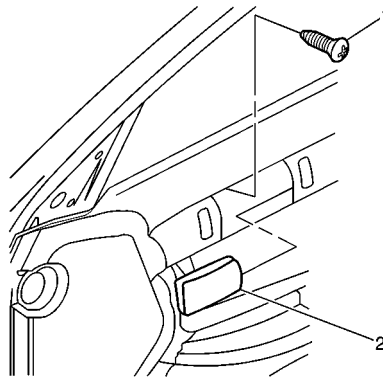

Figure 1 Removing Bezel

4. Remove the fastener (1) as shown in Figure 1.

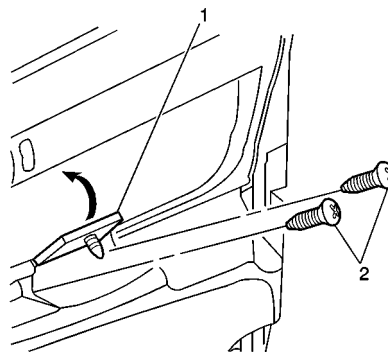

Figure 2 Lift the flap (1) in pull handle opening.

5. Lift the flap (1) in pull handle opening and remove the two fasteners (2) as shown in Figure 2.

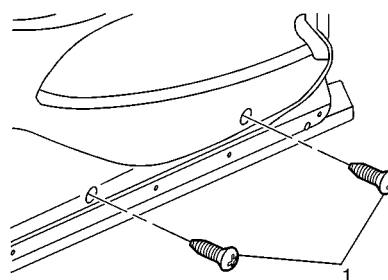

Figure 3 Removing fasteners from trim panel bottom

A6/U10/L1 MISCELLANEOUS SYSTEMS DIAGNOSIS AND REPAIR

- Remove the two fasteners (1) from bottom of trim panel as shown in Figure 3.

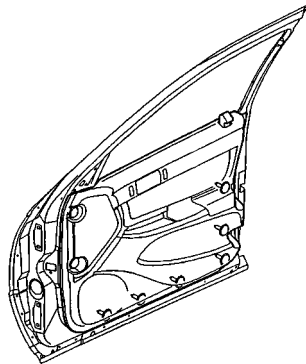

Figure 4 Removing the 8 Door Panel Retainers

- Release the eight retainers as shown in Figure 4 using what type of tool? _____
- Lift upward and outward on the door trim panel.

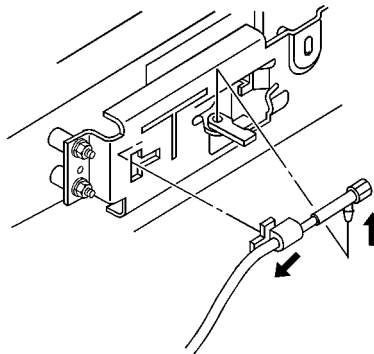

Figure 5 Disconnect the door latch cable

- Disconnect the door latch cable (Figure 5) from the inside door handle.
- Pry the tab on the cable outboard while pulling back on the cable.
- Unhook the collar portion of the clip from the cable attachment.
- Push upward on the bottom of the cable attachment to disengage the cable from the handle clip.
- Disconnect the electrical connectors and remove the door trim panel.
- Reinstall in reverse order.
- Do you have to replace the door panel replacement clips? _____

A6/U10/L1 MISCELLANEOUS SYSTEMS DIAGNOSIS AND REPAIR

TASK SUMMARY

- Now that you have completed this NATEF task, can you think of anything (tools, information, knowledge etc.) that would have made this task easier.

- List a customer complaint together with the cause that might appear on a work order, which would require this task as the correction.

COMPLAINT: _____

1. Perform Checks/Inspect: _____

2. Referencing Bulletin: _____

CAUSE: _____

1. Diagnosis: _____

2. Operating as designed: _____

3. Cause identified as: _____

CORRECTION: **THIS NATEF TASK JOB SHEET**

1. Other Correction: _____

2. Correction Verified By: _____

Use this Rubric to RATE the completion of Job Sheet

1 = Demonstrated exposure/observation of the competency

2 = Applies the competency but only mastered a few essential attributes of the competency

3 = Capable of the competency but needs further practice

4 = Performs the competency satisfactorily

5 = MASTERED the competency

Instructor _____ **Mentor** _____